

I11. #2 (DOWN SHIFT)

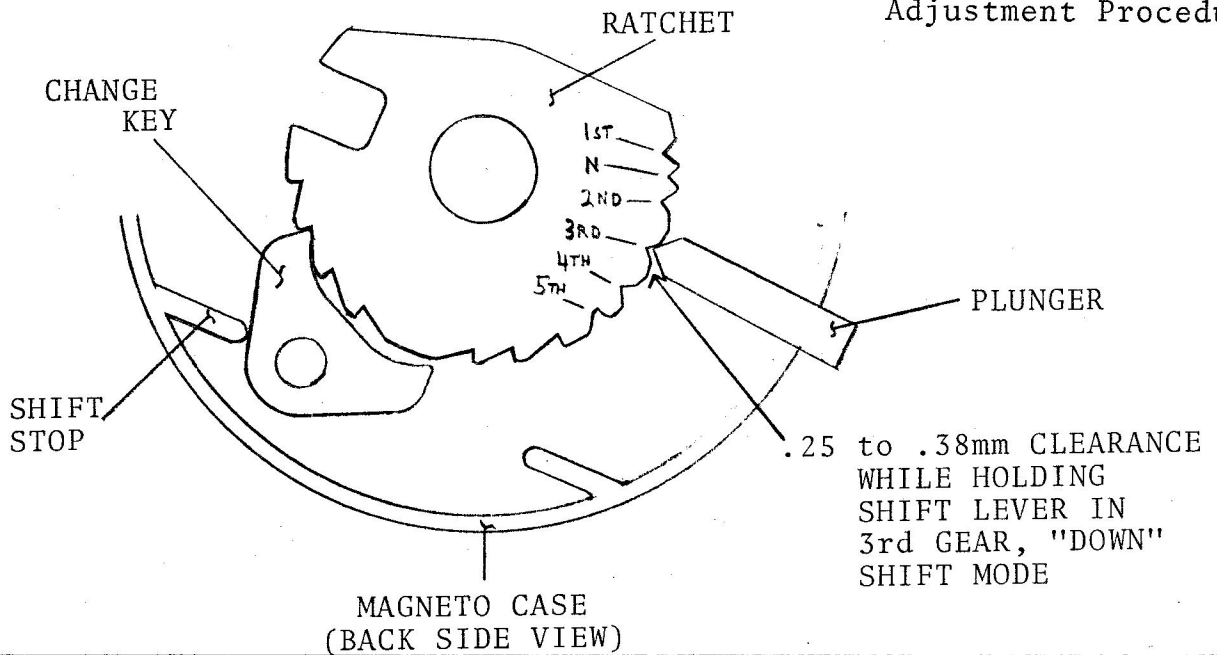

I11. #3 ADJUSTMENT OF SHIFTER RATCHET MECHANISM

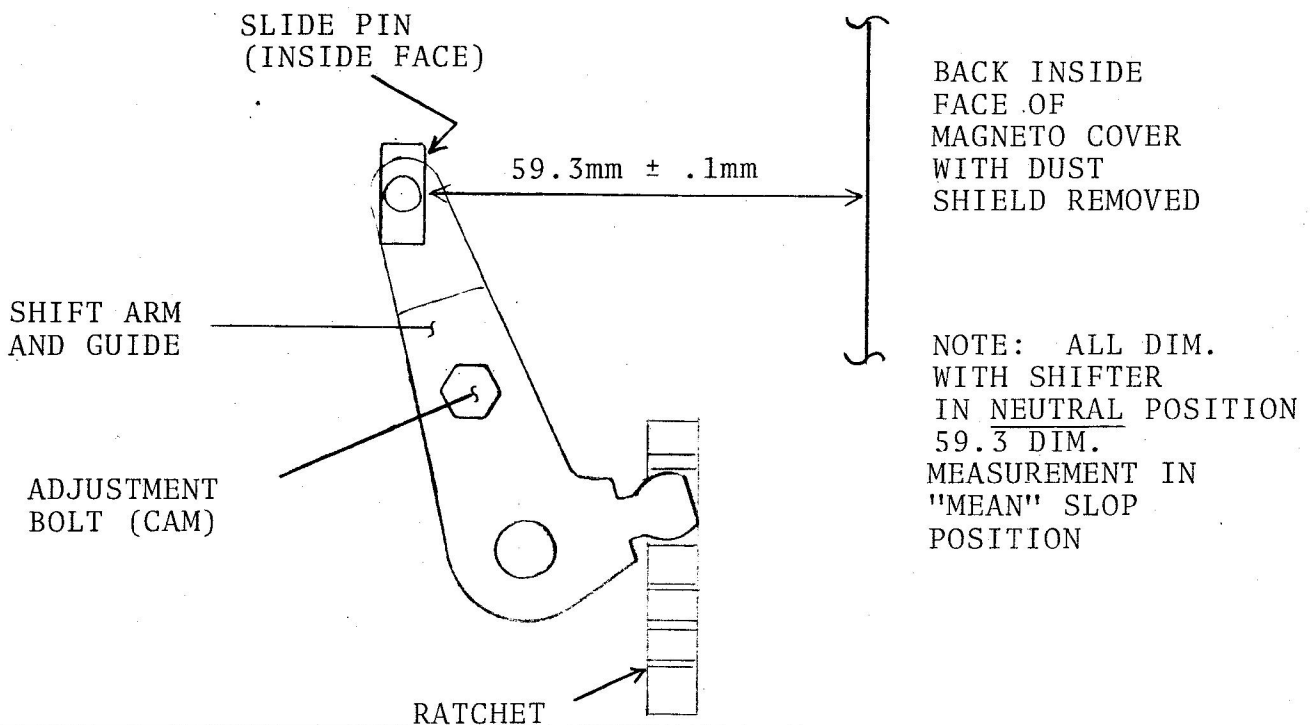

I11. #4 CHANGE KEY

